



DeltaPAT
MI 3309
Short instructions

Version UK 1.0, Code no. 20 751 869

Distributor:

Manufacturer:

Metrel d.d.
Ljubljanska cesta 77
SI-1354 Horjul

E-mail: metrel@metrel.si
<http://www.metrel.si>

© 2011 Metrel

 Mark on your equipment certifies that this equipment meets the requirements of the EU (European Union) concerning safety and electromagnetic compatibility regulations
--

No part of this publication may be reproduced or utilized in any form or by any means without permission in writing from METREL.

Table of contents

1	Start-up guide	4
1.1	Safety and operational considerations	4
1.2	Instrument description - Front and connector panel	5
1.3	Instrument description - Meaning of symbols	5
1.4	Battery and charging	8
1.5	Replacing the fuses	9
1.6	Warranty & Repairs	10
1.7	Contact Metrel UK	11
2	Quick-test guide	12
2.1	Instrument test modes	12
2.2	Carrying out a Simple test	12
2.3	Carrying out a Shortcut test sequence	13
2.4	Carrying out a Single test	13
2.5	Measurements.....	13
2.5.1	<i>Earth Continuity</i>	13
2.5.2	<i>Insulation resistance</i>	14
2.5.3	<i>Insulation-P resistance</i>	15
2.5.4	<i>Substitute leakage</i>	15
2.5.5	<i>Substitute leakage-P current</i>	16
2.5.6	<i>Polarity</i>	17
2.5.7	<i>Differential leakage</i>	17
2.5.8	<i>Touch leakage</i>	18
2.5.9	<i>(P)RCD test</i>	19
2.5.10	<i>Power</i>	20
2.5.11	<i>Voltage TRMS</i>	20
3	Step by step PC SW installation	21

1 Start-up guide

1.1 Safety and operational considerations

- ›  **Warning on the instrument means »Read the Instruction manual with special care to safety operation«. The symbol requires an action!**
- › **Read this instruction manual carefully, otherwise use of the instrument may be dangerous for the operator, for the instrument or for the equipment under test!**
- › **If the test equipment is used in manner not specified in this instruction manual the protection provided by the equipment may be impaired!**
- › **Do not use the instrument and accessories if any damage is noticed!**
- › **Do not touch any test leads/terminals while the appliance is connected to the MI 3309 DeltaPAT.**
- › **Consider all generally known precautions in order to avoid risk of electric shock while dealing with hazardous voltages!**
- › **Use only correctly earthed mains outlets to supply the instrument!**
- › **The mains supply voltage has to be higher than 80 V a.c. otherwise the internal power supply could be damaged.**
- › **Use only standard or optional test accessories, supplied by your distributor!**
- › **Instrument servicing and adjustment have to be carried out by competent authorized personnel!**
- › **Hazardous voltages can exist inside the instrument. Disconnect all test leads, remove the power supply cable and switch off the instrument before opening the battery or fuse compartment.**
- › **Instrument contains rechargeable NiCd or NiMh battery cells. The cells should only be replaced with the same type as defined on the battery placement label or in this manual.**
- › **If a test code with an earth continuity test current higher than 200 mA is selected (manually, with barcode scanner or with RFID reader/writer) the DeltaPAT instrument will automatically perform the Earth continuity test with a 200 mA test current. Other test parameters remain unchanged. The operator must be competent to decide if performing the test with a 200 mA current is acceptable!**

1.2 Instrument description - Front and connector panel



Instrument description:

1. Display
2. FAIL indicator
3. PASS indicator
4. TEST key
5. UP key
6. DOWN key
7. MEM key
8. TAB key
9. ON/OFF (2 sec), ESC key
10. Test socket

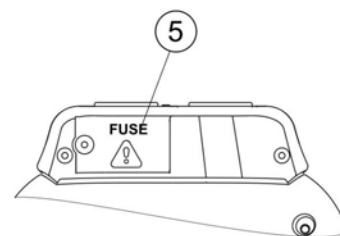
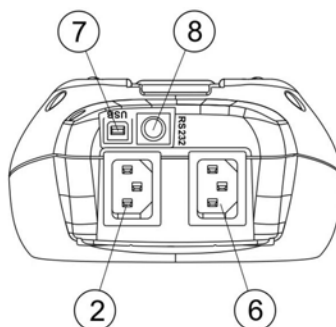
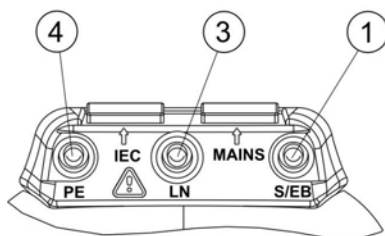

Connectors

1. S/EB1 Probe and Earth continuity terminal
2. IEC test terminal
3. LN terminal (for connection of fixed installed appliances)
4. PE terminal (for connection of fixed installed appliances)
5. Fuses: 2 x T16 A / 250 V, breaking capacity: 1500 A
6. Mains supply connector and test terminal
7. Communication with PC USB (1.1) port
8. PS/2 connector for communication with barcode scanner, printer, RFID reader/writer and PC (RS-232)

1.3 Instrument description - Meaning of symbols

Warnings

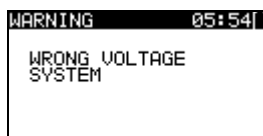

WARNING!

Improper supply voltage warning. Possible causes:

- no earth connection or other wiring problem on supply socket,
- instrument is connected to 110 V or IT earthing supply system.

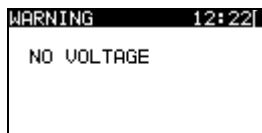
**WARNING!**

No voltage was detected on the mains input. Check mains connection.

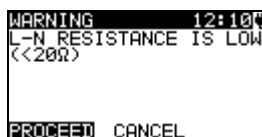
**WARNING!**

A low resistance of the appliance' supply input was measured in the pre-test. This means that most likely a high current will flow after applying power to the tested appliance. If the high current is only of short duration (caused by a short inrush current) the test can be performed, otherwise not.

Select **PROCEED** or **CANCEL**.

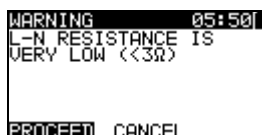
**WARNING!**

A very low resistance of the appliance' supply input was measured in the pre-test. It is likely that fuses will blow after applying power to the tested appliance. If the too high current is only of short duration (caused by an inrush current) the test can be performed otherwise it must be stopped.

Select **PROCEED** or **CANCEL**. It is recommended to additionally check the appliance before proceeding with the test!

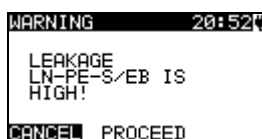
**WARNING!**

A high leakage current (higher than 3.5 mA) will flow if power would be connected to the tested appliance.

Select **PROCEED** or **CANCEL**. Proceed with testing only if all safety measures have been taken.

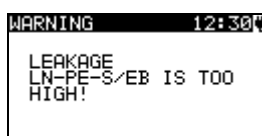
**WARNING!**

A dangerous leakage current (higher than 20 mA) will flow if power would be connected to the tested appliance. The instrument blocks the test.

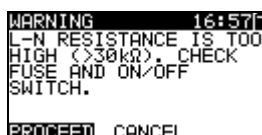
**WARNING!**

A high resistance between L and N was measured in the fuse pre-test. This indication means that the device under test has very low power consumption or it is:

- ▶ not connected;
- ▶ switched off;
- ▶ contains a fuse that has blown.

Select **PROCEED** or **CANCEL**.

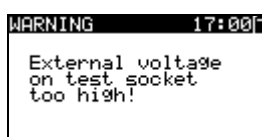
**WARNING!**

Voltage on test socket or IEC test terminal is higher than approximately 20 V (AC or DC)!

Disconnect the device under test from the instrument immediately and determine why an external voltage was detected!

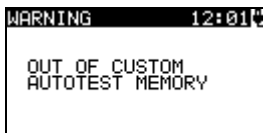

WARNING!

The custom autotest memory has reached the limit of 50 sequences.

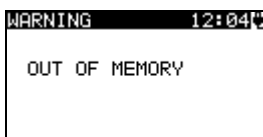

WARNING!

The internal memory is full!

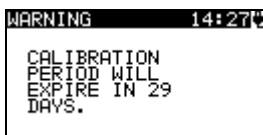

WARNING!

The calibration period will expire in less than 1 month. The instrument counts down the days.

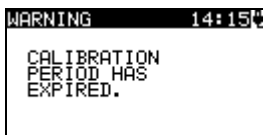

WARNING!

The calibration period has expired. Recalibrate the instrument!

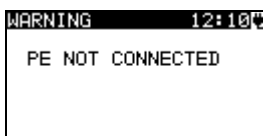

PE between test socket and IEC test terminal is not connected!

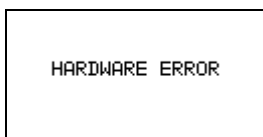

The instrument detects a serious failure. Switch OFF the instrument. Disconnect all cables and leads. Switch ON the instrument again. **Return the instrument to the repair centre if the message is displayed again.**

Symbols



WARNING!

A high voltage will be present on the output of the instrument!



WARNING!

A high insulation test voltage is present on the output of the instrument.



Measurement is in progress.



Test result can be saved.



Connect the test lead to the S/EB test terminal.



Flex the mains cable of appliance during the test.



Check that the device under test is switched on (to ensure that the complete circuit is tested).



Connect the cord to be tested to the IEC test terminal.



Indicate which connection in the test socket is over the limit (blank contact - under limit, filled contact - over limit)



RCD must be switched on.



Change position of mains cord before RCD test.



Test passed.



Test failed.



Measurement was aborted due to improper conditions during the test.

Battery and charging indications



Battery capacity indication.



Low battery.
Battery is too weak to guarantee correct result.
Replace or recharge the battery cells.



Instrument is connected to the mains (and is charging)

1.4 Battery and charging

- › When replacing battery cells or before opening the battery compartment cover, disconnect all test leads / accessories connected to the instrument and switch off the instrument. Hazardous voltage can exist inside the instrument!
- › Insert all the battery cells correctly! If this is not performed correctly, the instrument will not operate and the batteries could be discharged.
- › If the instrument is not used for a long period of time, remove all of the batteries from the battery compartment to protect the instrument from battery acid leakage.
- › Rechargeable NiCd or Ni-MH battery cells (size AA) can be used.

The battery is charged whenever the instrument is connected to mains voltage. The instrument automatically recognizes the connection to the mains voltage and begins charging. Internal circuit controls charging and assures maximum battery lifetime.

WARNING!

- › Alkaline battery cells are not allowed.

1.5 Replacing the fuses

The DeltaPAT MI 3309 instrument contains two accessible fuses:

- F1, F2 fuse type:
T 16 A / 250 V, 20×5 mm, breaking capacity 1500 A
General input protection fuses.

WARNINGS!

- Disconnect all measuring accessories, mains supply and power off the instrument before opening the battery or fuse compartment cover, hazardous voltage inside!
- Replace blown fuse with same type only, otherwise the instrument may be damaged and / or operator's safety impaired!

Position of fuses F1, F2 can be seen in chapter 1.2 Instrument description - Front and connector panel

1.6 Warranty & Repairs

Metrel UK's instruments have a three year warranty against defects in materials or workmanship. Accessories and other supplementary products have a one year warranty against defects in materials or workmanship.

Any potentially defective items should be returned to Metrel accompanied by information regarding the faults that was incurred. It is recommended that any defective equipment is sent back to Metrel via the wholesaler from which the product was purchased.

All defective products will be replaced or repaired within policy period. For these items, a full refund will only be issued if a sufficient replacement is not available. Any shipping / return-shipping costs are not refundable.

Metrel UK shall not be held liable for any loss or damage resulting from the use or performance of the products. In no event shall Metrel UK be liable to the customer or its customers for any special, indirect, incidental, exemplary or punitive damages resulting from loss of use, interruption of business or loss of profits, even if Metrel UK has been advised of the possibility of such damages.

If the customer's unit is out of warranty but needs repairs a quote for repair will be provided via the wholesaler through which the instrument was sent in.

Notes:

- Any unauthorized repair or calibration of the instrument will infringe the product's warranty.
- All sales are subject to Metrel UK's Standard Terms and Conditions, a full copy of which is available Metrel UK's office. Metrel UK reserves the right to change the conditions at any time. Any typographical, clerical or other error or omission in any sales literature, quotation, price list, acceptance of offer, invoice or other documentation or information issued by Metrel UK shall be subject to correction without any liability on the part of the customer.
- Specifications and designs of goods are subject to change by Metrel UK at any time without notice to the customer. Metrel UK reserves the right to make any changes in the specification of goods which are required to conform with any applicable statutory or EC requirements or, where goods are to be supplied to Metrel UK's specification, which do not materially affect their quality or performance.
- If a condition was found to be invalid or void it would not affect the overall validity of the remainder of the conditions;
- Metrel UK are excluded from liability for any delays or failure to comply, where the reason is beyond Metrel UK's control;
- No order which has been accepted by Metrel UK may be cancelled by the customer except with the agreement in writing of Metrel UK and on terms that the customer shall indemnify Metrel UK in full against all loss (including loss of profit), costs (including the cost of all labour and materials used), damages, charges and expenses incurred by Metrel UK as a result of cancellation. The minimum charge for such cancellation will be 25 % of the total value of the goods ordered.

1.7 Contact Metrel UK

Metrel UK
Unit 1, Hopton House, Ripley Drive
Normanton Industrial Estate
Normanton,
West Yorkshire
WF6 1QT

Tel.: +44/ (0) 1924 24 50 00

Fax: +44/(0) 1924 24 50 07

E-mail: info@metrel.co.uk

Web: www.metrel.co.uk

Update your meter

Metrel offers a service of updating your software or firmware to the latest developments. Register on www.metrel.co.uk to receive updates of PC SW and firmware of the meters.

Calibrate your Meter

Metrel offers a calibration service of all Metrel equipment. Contact Metrel UK on 01924 245000 and ask for the calibrations department.

Repair

Metrel offers a repair service of all Metrel equipment. Contact Metrel UK on 01924 245000 and ask for the repairs department.

Ask a technical question

Metrel offers a Technical Advice Line every Mon-Thu from 8:00 a.m. till 5.00 p.m. and Fridays from 8:00 a.m. till 4 p.m..

Get training on Metrel meters

Metrel offers training on site or at the office subject to a charge.

2 Quick-test guide

2.1 Instrument test modes

Instrument has three main operation modes.

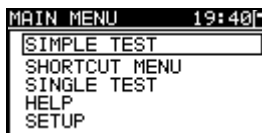

- › <**SIMPLE TEST**> simple pre-programmed sequences; test sequences can be user customized.
- › <**SHORTCUT MENU**> code-based test sequences, suitable for working with barcodes.
- › <**SINGLE TEST**> individual tests.
- › <**HELP**> help screens.
- › <**SETUP**> menu for setup of the instrument.

2.2 Carrying out a Simple test

① **Set function**

In Main menu select **SIMPLE TEST**.

MAIN MENU	19:40
SIMPLE TEST	
SHORTCUT MENU	
SINGLE TEST	
HELP	
SETUP	

② **Select the appropriate test sequence**

SIMPLE TEST	12:13
CLASS I	
CLASS II	
IEC	
CLASS I PC	

③ **Carry out the simple test sequence**

Press TEST to start test sequence

Certain tests will pre-select limits but will allow the user to adjust (if required).

④ **View results**

After test sequence is finished Autotest Result screen and an overall PASS/FAIL indication is displayed.

AUTOTEST RESULT	17:05
OVERALL:	✓
VIEW RESULTS	
NEW TEST	
SAVE RESULTS	

2.3 Carrying out a Shortcut test sequence

① **Set function**

- In Main menu select **SHORTCUT MENU**.

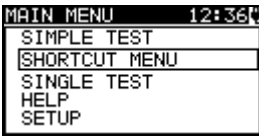

② **Set appliance type and protective measures**

- Use the TAB and UP and DOWN arrows to set the appliance type, class etc or select (scan) the appropriate code.



③ **Carry out Shortcut autotest sequence**

- Press TEST to Start autotest
- Certain tests will preselect limits but will allow the user to adjust (if required).

④ **View results**

- After Shortcut test sequence is finished. Autotest Result screen and an overall PASS/FAIL indication is displayed.

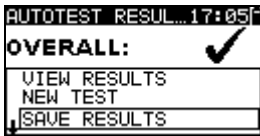

2.4 Carrying out a Single test

① **Set function**

- In Main menu select **SINGLE TEST**.

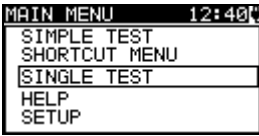

② **Select the appropriate Single test**

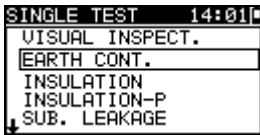

③ **Carry out measurement or inspection**

- Press TEST to start single test
- Certain tests will allow limits to be set (if required).

④ **View results**

- After test is finished Result screen and PASS/FAIL indication is displayed

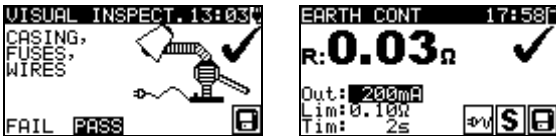

2.5 Measurements

2.5.1 Earth Continuity

① **Set function**



② **Set parameters and limits**

Output.... Size of test current
Limit Maximum earth continuity resistance
Time..... Test time.

③ Connect the appliance to the instrument (as illustrated)

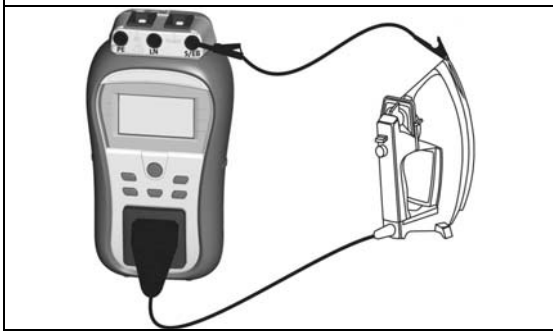

④ Carry out the test 

⑤ View results

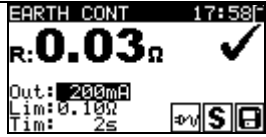
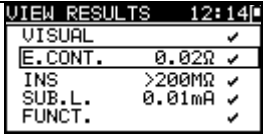
	
---	--

2.5.2 Insulation resistance

① Set function



② Set parameters and limits

Output ... Size of test voltage
 Limit..... Minimum insulation resistance
 Time..... Test time.

③ Connect the appliance to the Instrument (as illustrated)

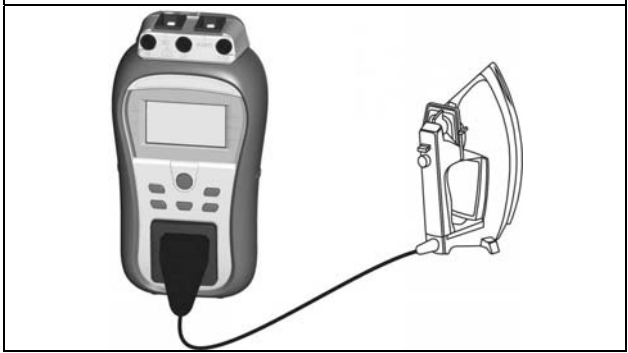





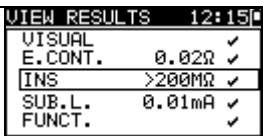

④ Carry out the test 

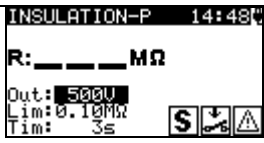
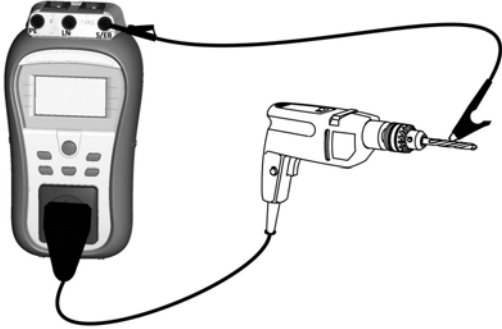
⑤ View results

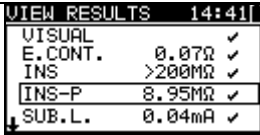
	
---	--

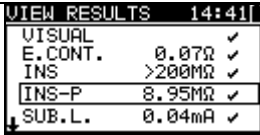
2.5.3 Insulation-P resistance

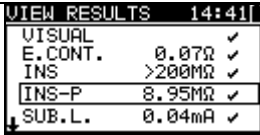
<p>① Set function</p> 	<p>② Set parameters and limits</p> <p>Output ... Size of test voltage Limit..... Minimum insulation resistance Time..... Test time.</p>		
<p>③ Connect the appliance to the Instrument (as illustrated)</p> 	<p>④ Carry out the test TEST</p>		
<p>⑤ View results</p> <table style="width: 100%; border-collapse: collapse;"> <tr> <td style="width: 50%; border: 1px solid black; padding: 5px;">  </td> <td style="width: 50%; border: 1px solid black; padding: 5px;">  </td> </tr> </table>			
			

2.5.4 Substitute leakage

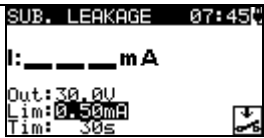
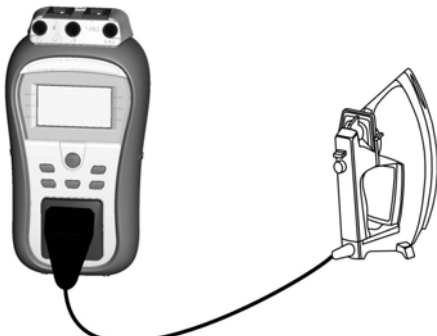
<p>① Set function</p> 	<p>② Set parameters and limits</p> <p>Output ... Size of test voltage Limit..... Maximum leakage current Time..... Test time.</p>
<p>③ Connect the appliance to the Instrument (as illustrated)</p> 	<p>④ Carry out the test TEST</p>

5 View results

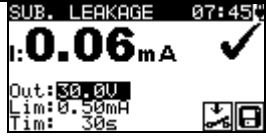
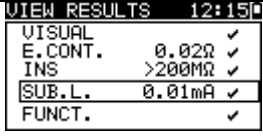
	
---	--

2.5.5 Substitute leakage-P current

1 Set function



2 Set parameters and limits

Output.... Size of test voltage
 Limit..... Maximum touch leakage current
 Time Test time.

3 Connect the appliance to the Instrument (as illustrated)

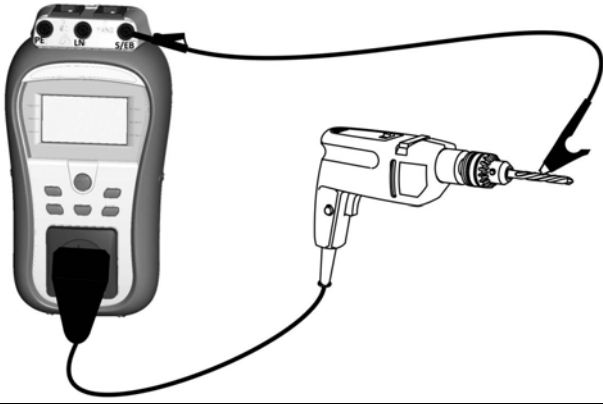







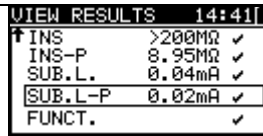

4 Carry out the test

TEST

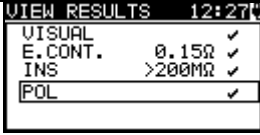

5 View results

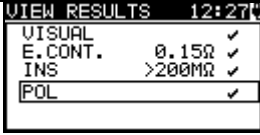
	
---	--

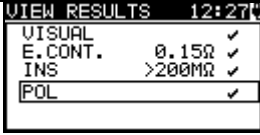
2.5.6 Polarity

<p>① Set function</p> 			
<p>② Connect the IEC cable to the instrument (as illustrated)</p> 	<p>③ Carry out the test </p>		
<p>④ View results</p> <table style="width: 100%; border-collapse: collapse;"> <tr> <td style="width: 50%; border: 1px solid black; padding: 5px;">  </td> <td style="width: 50%; border: 1px solid black; padding: 5px;">  </td> </tr> </table>			
			

2.5.7 Differential leakage

<p>① Set function</p> 	<p>② Set parameters and limits</p> <p>Limit Maximum diff. leakage current Time Test time.</p>
<p>③ Connect the appliance to the Instrument (as illustrated) and supply the instrument from mains.</p>	<p>④ Carry out the test </p>

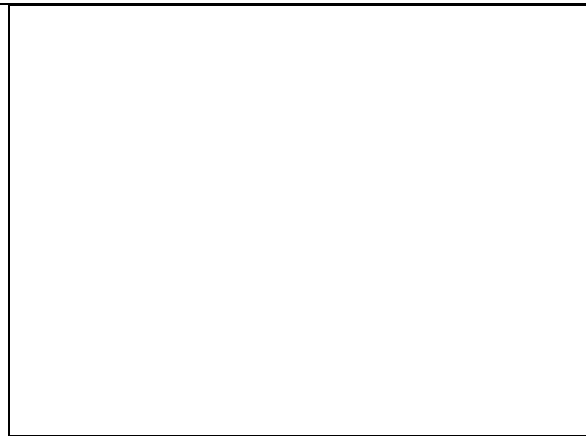
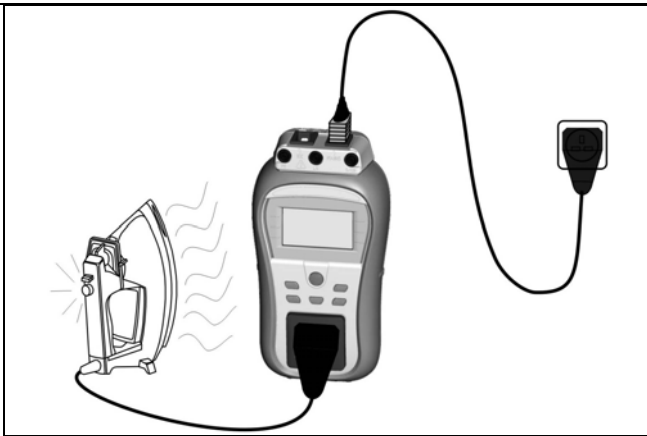

⑤ View results

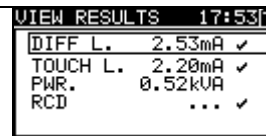

2.5.8 Touch leakage

① Set function

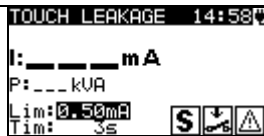

② Set parameters and limits

Limit Maximum touch leakage current
Time Test time.

③ Connect the appliance to the Instrument (as illustrated) and supply the Instrument from mains.

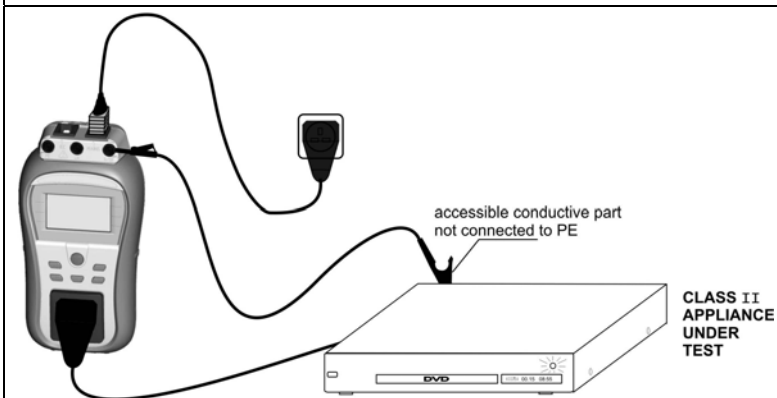

④ Carry out the test TEST



⑤ View results

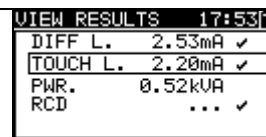

2.5.9 (P)RCD test

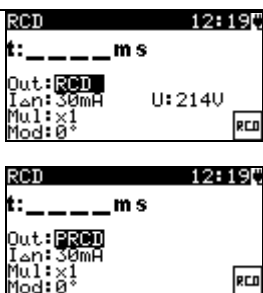
<p>① Set function</p> 	<p>② Set parameters and limits</p> <p>Out Test function $I_{\Delta N}$ Rated residual current Mul Test current multiplier Mod test mode</p>
--	--

③ Connect (P)RCD to the Instrument (as illustrated) and supply the Instrument from mains.

RCD:

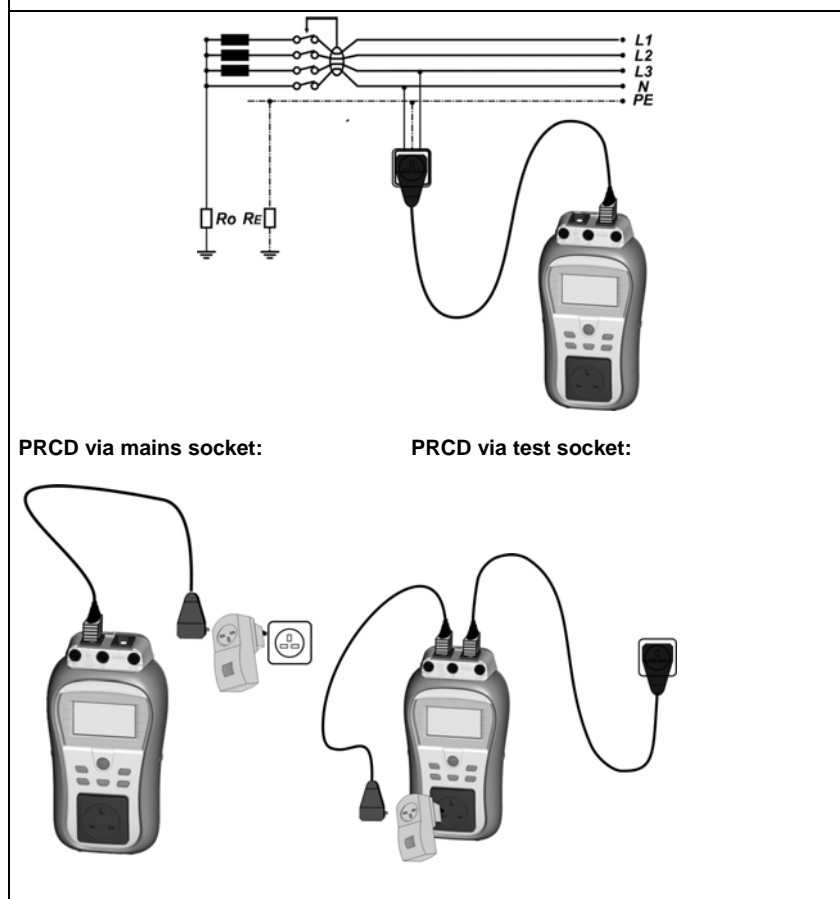

④ Carry out the test

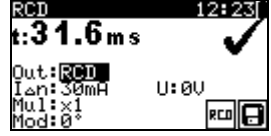
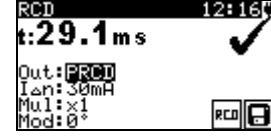
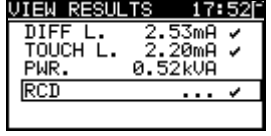

⑤ View results

		
---	---	---

2.5.10 Power

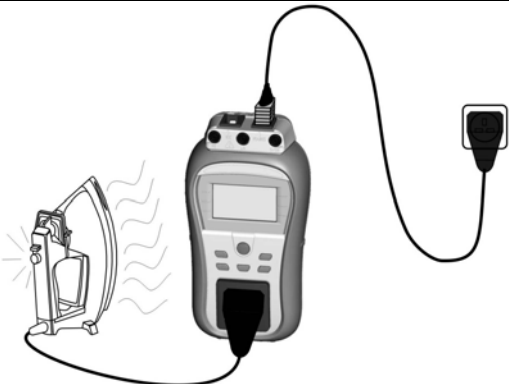
<p>① Set function</p> 	<p>② Set parameters and limits</p> <p>Time Test time.</p>
<p>③ Connect the appliance to the Instrument (as illustrated) and supply the Instrument from mains.</p> 	<p>④ Carry out the test TEST</p>
<p>⑤ View results</p> <div style="display: flex; justify-content: space-around;"> <div style="border: 1px solid black; padding: 5px; width: 45%;"> <p>POWER 07:58</p> <p>P: 1.53 kVA</p> <p>Tim: 120s</p> </div> <div style="border: 1px solid black; padding: 5px; width: 45%;"> <p>VIEW RESULTS 17:53</p> <p>DIFF L. 2.53mA ✓</p> <p>TOUCH L. 2.20mA ✓</p> <p>PWR. 0.52kVA</p> <p>RCD ... ✓</p> </div> </div>	

2.5.11 Voltage TRMS

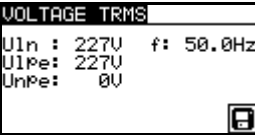
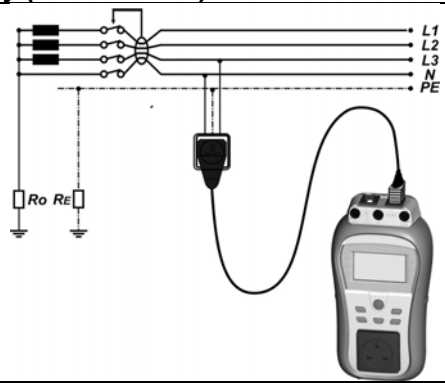
<p>① Set function</p> 	<p>② Connect the Instrument to the mains supply (as illustrated)</p> 
<p>③ Carry out the test</p> <p>The voltage measurement will start automatically!</p>	

3 Step by step PC SW installation

PAT Link PRO and PAT Link PRO Plus

Important: The user should have full administrative privileges, in case Windows 7 is installed on your computer. Read the document in section Installing instructions → Privileges troubleshooting on windows 7.

1. Insert a CD delivered with the instrument into the CD/DVD drive of your computer.
2. The software should run automatically. If this is not the case, double click on the CD/DVD drive icon on your computer to open the contents of the CD and double click on the “METREL.exe” program file.
3. The initial welcome screen will appear, select the language, area location and product name.



Language selection



Area selection

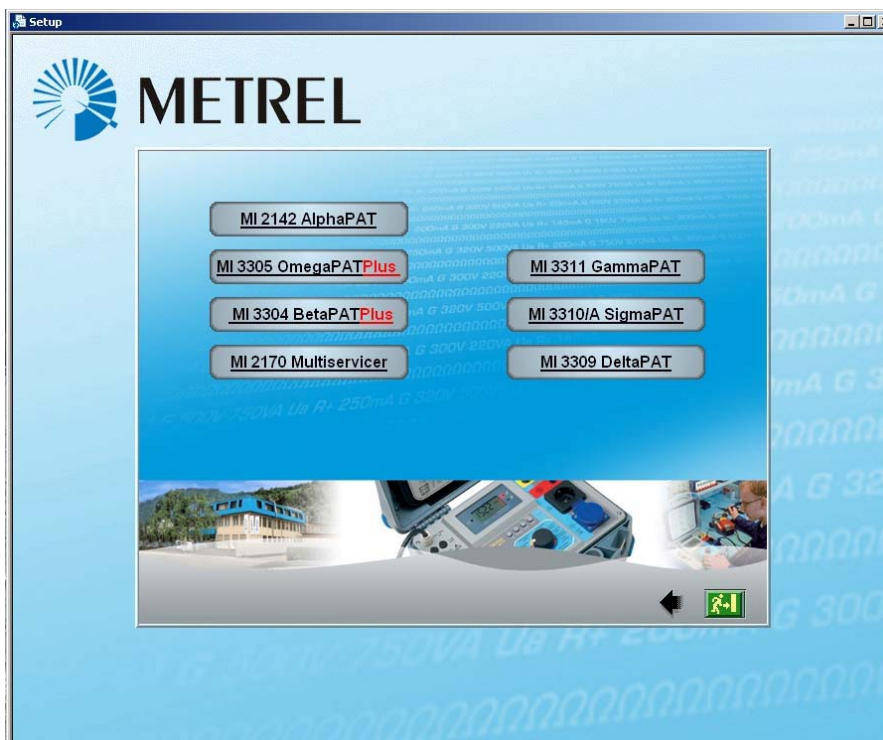

Product name selection

4. To install the software, Select PATLink PRO in the next screen

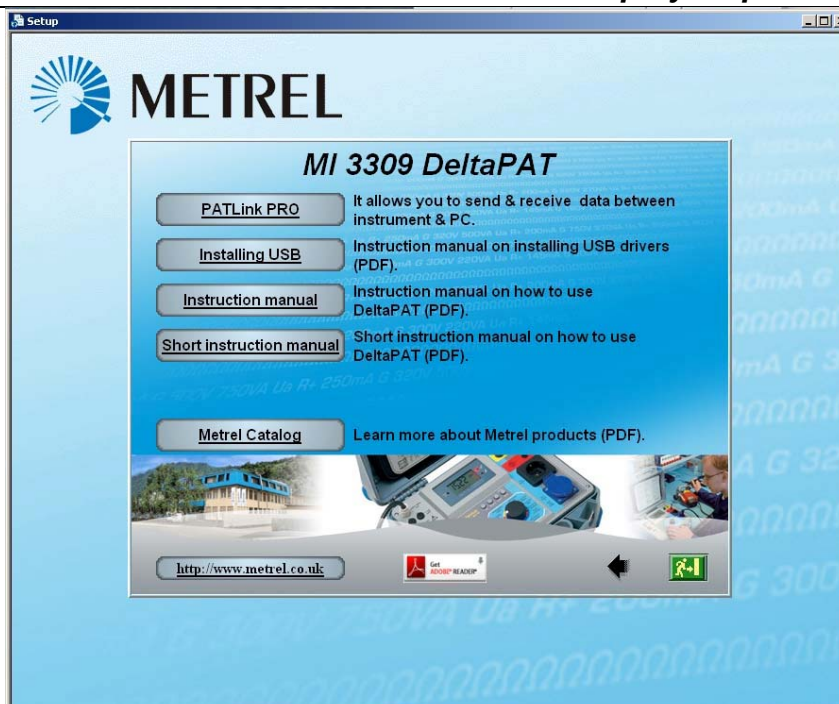

Product section

5. The installation of the software will now begin, on the welcome screen Select »Next« and follow the setup instructions.

6. After completing the installation, confirm finishing the installation leave the check box ticked to automatically start the program (a shortcut is automatically placed on the desktop and in the start menu for future software initiations).

7. To start PAT Link PRO software, click the shortcut on the desktop or in the start menu Help files are available on the software to guide you through the various sections of the software.

8. Select "Installing USB".

Read carefully Installing USB instruction manual available on CD and follow the instruction on how to establish connection between instrument and PC and download the data.

The USB drivers will be automatically installed on the windows 7 operating system.

